

# 689-52 Rev 3 FSK Card Reader Module

## Data Sheet

The 689-52 FSK card reader module is a fully encapsulated device that will read the code from an HID H10301/4 transponder and output the code in one of many user selectable formats. The module contains all the detection circuitry required to implement a proximity reader including an internal coil antenna. A larger external reader coil may be connected if greater reading range is required.

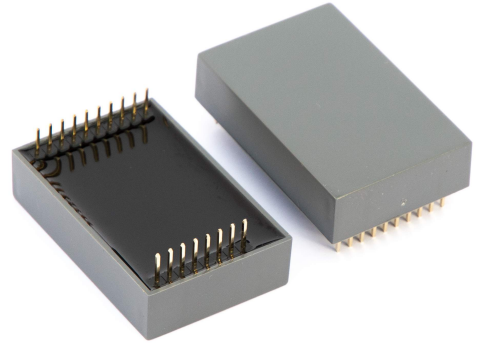

### Specifications

- Power requirements: either regulated 5V dc or unregulated 5.5V – 12V dc. Current consumption: 65mA (typ); 95mA (max. all conditions)
- RF Frequency: 125 kHz
- Card types supported: HID H10301 (26 bit format); HID H10304 (37 bit format)
- Output formats supported: Wiegand; Mag stripe emulation; Clock/Data; RS232-TTL (9600,n,8,2) 5V TTL levels
- Continuous output with tag in field or single transmission
- Typical read range with internal coil: 60 mm for ISO cards, 30 mm for keyring tag
- External coil connection for remote reading or extended read range
- Connection for piezo beeper: 4 kHz PWM; 50 ms beep on card read
- Operating temperature range: -10 °C to +50 °
- Weight: ~20 grams

### Pinout Description and Dimensions

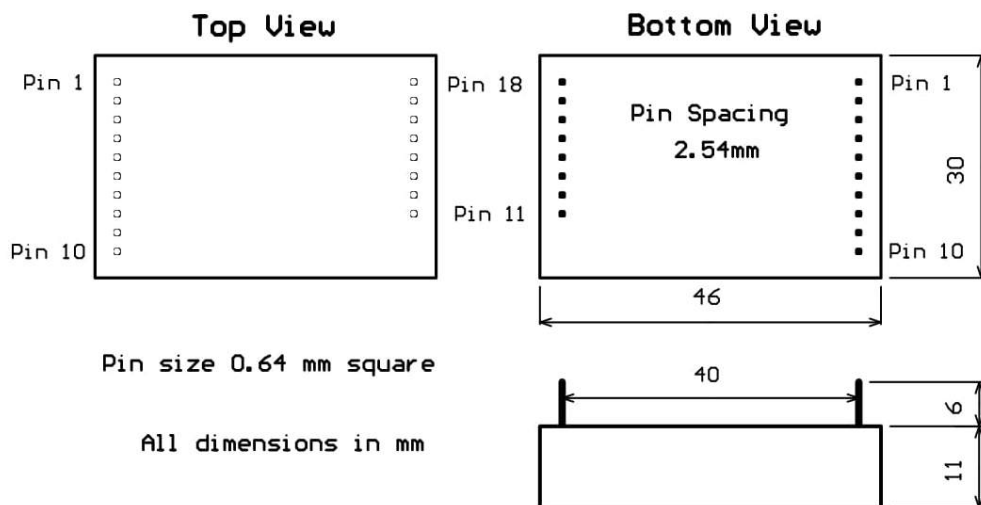

Pin #	Pin Name	Function
1	DETECT	Output: drives LOW for duration of output transmission <sup>1</sup>
2	CLOCK/DATA0	Output: outputs tag code in selected format <sup>1</sup>
3	DATA/DATA1	Output: outputs tag code in selected format <sup>1</sup>
4	CONTINUOUS	Input: connect to 0V for continuous transmission mode. Connect to +5V or leave floating for single transmission mode <sup>2</sup>
5	INVERT	Input: connect to 0V to invert the output on pins 1,2 and 3 <sup>2,3</sup>
6	SELECT1	Input: connect to 0V or leave floating to select different output formats <sup>2</sup>
7	SELECT2	
8	SELECT3	
9	SELECT4	
10	RESERVED	Leave disconnected
11	COIL A	Coil driver: connect to COIL LINK for internal coil or connect to external coil <sup>4</sup>
12	COIL LINK	Link to COIL A to for internal coil or leave disconnected for external coil
13	COIL B	External coil connection
14	RAW DATA	Output: raw data stream detected from tag
15	BEEPER	Output: open collector PWM drive for external piezo beeper
16	+5V	Power: operation of module from 5V
17	+12V	Power: operation of module from 5.5V to 12V
18	0V	Power: connect to 0V of power supply

[1] 5V logic,  $Z_{out} \approx 1.2k$

[2] Inputs are pulled HIGH internally, may be left floating

[3] Current consumption increases +15mA for inverted outputs

[4] Can use series resistor of value  $4.7 \Omega - 10 \Omega$  (100mW) to reduce module current, trades off read range - (same arrangement can also be used with external coil)

## Output Mode Selection

The module has four selection pins (SELECT1 ... SELECT4). These pins are internally pulled HIGH in the module. To select the different output formats the SELECT pins may be tied to 0V (indicated as 0) or left unconnected (indicated as 1) according to the following table:

SELECT4	SELECT3	SELECT2	SELECT1	Output format
0	0	0	0	Inhibit – turn off coil
0	0	0	1	Unused
0	0	1	0	Unused
0	0	1	1	RS232-TTL – long number format
0	1	0	0	Unused
0	1	0	1	Unused
0	1	1	0	Unused
0	1	1	1	RS232-TTL – site/card format
1	0	0	0	Mag Stripe - fast
1	0	0	1	Unused
1	0	1	0	Unused
1	0	1	1	Mag Stripe – slow
1	1	0	0	Basic Clock/Data
1	1	0	1	Unused
1	1	1	0	Unused
1	1	1	1	Wiegand

## Power Connections

Power can be supplied to the module in two ways:

1. For voltages +5.5 to +12 volts connect power to pin 17 (+V) and pin 18 (0V); **do not exceed +12.6V**
2. Alternatively the internal regulator may be bypassed. Regulated +5V may be connected to pin 16 (+5V) and pin 18 (0V); **do not exceed +5.5V**

## External Beeper Connection

The module pin 15 (BEEPER) is an open collector output. It outputs a frequency of 4kHz for 50ms when a tag is read. Shown are two typical circuits that can be used to connect a beeper:

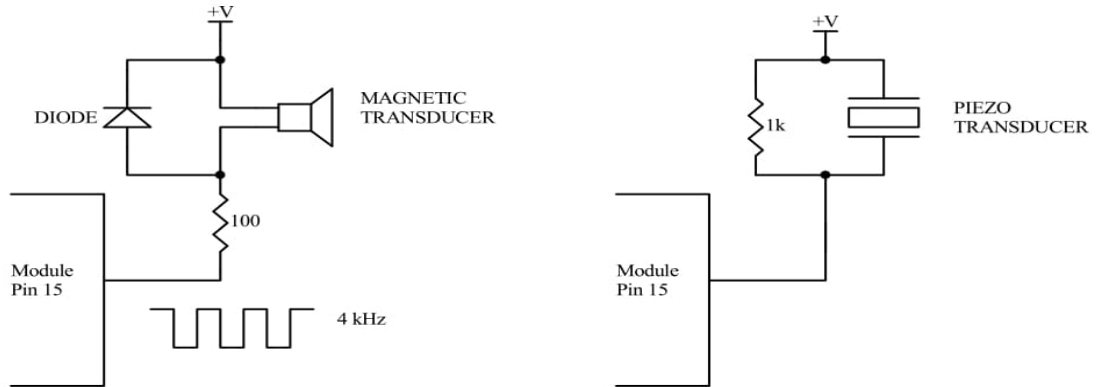

## Coil Connection

The module has an internal coil which may be suitable for many applications. The internal coil is selected by connecting pin 11 (COIL A) to pin 12 (COIL LINK). A resistor in the range of 4.7 to 10 ohms (100mW) may be used in series with the link to reduce the module current (read range may decrease).

If an external coil is required to obtain a greater reading range, a coil of 486uH to 508uH must be connected between pin 11 (COIL A) and pin 13 (COIL B), with COIL LINK unconnected (internal coil not used). A resistor in the range of 4.7 to 10 ohms (100mW) may be used in series with the external coil to reduce the module current (read range may decrease).

## Inverted Outputs

The polarity of DETECT (pin 1), CLOCK/DATA0 (pin 2) and DATA/DATA1 (pin3) may be inverted by connecting pin 5 (INVERT) to 0V. (Note. In this mode module current increases by +15mA).

In all modes the idle level of the output data pins (1, 2 and 3) is HIGH. This is acceptable when connecting the module directly to the receiving equipment over a short length. However when a long cable exists between the module and the receiving equipment it is desirable to include an open collector transistor stage between the module and the long cable as shown below:

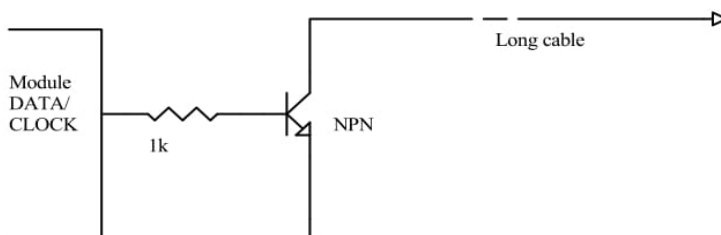

To ensure the idle state of the transistor is OFF, the idle level from the module output data pins must be LOW, to achieve this connect INVERT to 0V.

The INVERT pin has no effect on the RS232 output modes.

### Continuous mode

When pin 4 (CONTINUOUS) is connected to 0V the reader repeatedly transmits the tag code in the selected format every 100ms.

In SINGLE transmission mode (pin 4 floating) the reader transmits the tag code once only; the tag must be removed from the field for at least 1 second before the same tag can be re-read and the code re-transmitted.

### RS232-TTL Output modes

The RS232-TTL output from the module is on pin 3 (DATA). This output is suitable to connect directly to the UART of a microprocessor. The idle level is HIGH. The baud rate is 9600; data format is 8 bits, no parity and 2 stop bits.

To achieve true RS232 levels and polarity the module output should be connected to an EIA-232 DRIVER IC (e.g. MAX232).

### Long number format

The tag code is output in the following structure:

STX(02h)	DATA(ASCII)	CR(0Dh)	LF(0Ah)	ETX(03h)
----------	-------------	---------	---------	----------

The data bytes vary depending on the type of card presented to the reader:

#### H10301 (26 bit format)

DATA = 8 ASCII characters representing the 24 bits of the tag code converted to decimal, e.g. '11727146' (31 31 37 32 37 31 34 36 hex)

#### H10304 (37 bit format)

DATA = 11 ASCII characters representing the 35 bits of the tag code converted to decimal, e.g. '10280162602' (31 30 32 38 30 31 36 32 36 30 32 hex)

### Site/card number format

The tag code is output in the following structure:

STX (02h)	SITE CODE (ASCII)	SPACE (20h)	CARD NUMBER (ASCII)	CR (0Dh)	LF (0Ah)	ETX (03h)
--------------	----------------------	----------------	------------------------	-------------	-------------	--------------

The SITE CODE and CARD NUMBER bytes vary depending on the type of card presented to the reader:

#### H10301 (26 bit format)

SITE CODE = 3 ASCII characters representing the upper 8 bits of the tag code converted to a decimal number

CARD NUMBER = 5 ASCII characters representing the lower 16 bits of the tag code converted to a decimal number

The two numbers are separated by a SPACE = 20h ASCII

Example: a card with the following 24 data bits: 101100101111000100101010

Outputs: '178 61738' (31 37 38 20 36 31 37 33 38 hex)

#### H10304 (37 bit format)

SITE CODE = 5 ASCII characters representing the upper 16 bits of the tag code converted to a

decimal number

CARD NUMBER = 6 ASCII characters representing the lower 19 bits of the tag code converted to a decimal number

The two numbers are separated by a SPACE = 20h ASCII

Example: a card with the following 35 data bits: 01001100100101111101101010100101010

Outputs: '19607 447786' (31 39 36 30 37 20 34 34 37 37 38 36 hex)

### Wiegand Output Modes

In this mode the tag code is pulsed out on DATA0 (pin 2) and DATA1 (pin 3). Both are normally HIGH. When a tag is presented to the reader 26 (or 37) bits are transmitted in the following way:

A binary 1 is represented by a 100us pulse LOW on DATA1. A binary 0 is represented by a 100us pulse LOW on DATA0. There is a 2ms inter bit delay.

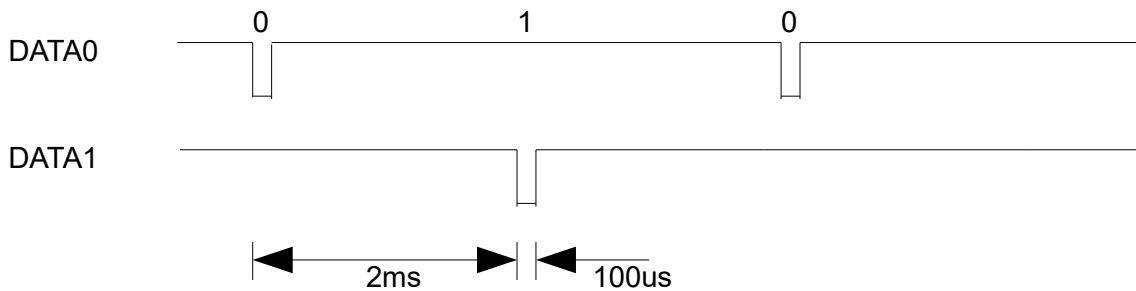

### H10301 (26 bit format)

All 26 bits of the card data are transmitted

### H10304 (37 bit format)

All 37 bits of the card data are transmitted

### Clock/Data Mode

In this mode all 40 bits of the tag code are clocked out with an eight bit header and an eight bit checksum

HEADER (11111110)	DATA (40 bits)	CHECKSUM
-------------------	----------------	----------

The HEADER is hex FE. The DATA consists of 40 tag code bits sent MSB first. The checksum is the byte addition of the 5 bytes of DATA bits, e.g. tag code 07FFFFFFFh has the checksum 07h+FFh+FFh+FFh+FFh=03h

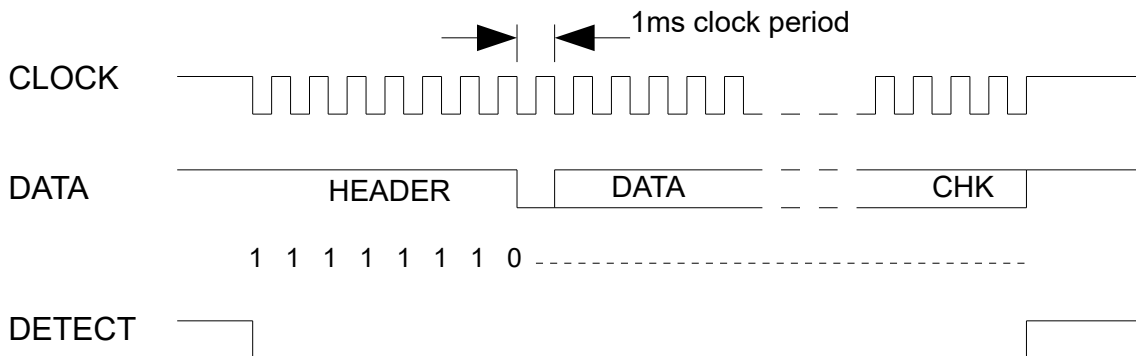

Data is set up on the falling edge of the clock and is stable on the rising edge of the clock.

When a H10301 card is presented to the reader the data bits will consist of 16 zero bits and 24 card data bits.

When a H10304 card is presented to the reader the data bits will consist of 5 zero bits and 35 cards data bits.

### Slow Mag Stripe Mode

In this mode the decimal tag number is clocked out on CLOCK (pin 2) and DATA (pin 3) at 100 characters per second. The format is standard as found on Track 2 of a magnetic card:

10 leading 0's	SS	DATA	ES	LRC	5 trailing 0's
----------------	----	------	----	-----	----------------

SS = start sentinel (B hex)

ES = end sentinel (F hex)

LRC = longitudinal redundancy check

The data varies depending on the type of card presented to the reader:

#### H10301 (26 bit format)

DATA = 8 decimal digits with leading zeros. The most significant decimal digit is transmitted first.

#### H10304 (37 bit format)

DATA = 11 decimal digits with leading zeros. The most significant decimal digit is transmitted first.

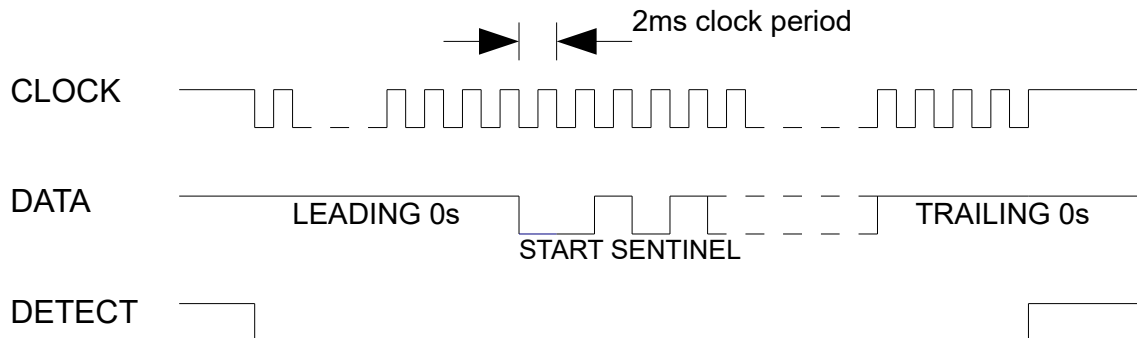

Each character is 5 bits long. The first four bits are the hex digit (0-F) least significant bit first. The fifth bit is the odd parity bit. A 0 is represented by a HIGH level on the DATA pin and a 1 is represented by a LOW level on the DATA pin. Data is set up on the falling edge of the clock and is stable on the rising edge of the clock. The DETECT output goes LOW for the duration of the transmission simulating the CARD DETECT from a mag. card reader.

### Fast Mag Strip mode

This mode differs from the slow mag stripe mode in the following ways:

- the clock period is 250us
- ends with 10 trailing zeros

All other aspects of this format are the same as the other mag stripe formats.